

## APV DELTA SWT4

TANK OUTLET VALVE

FORM NO.: H312162 REVISION: UK-1

READ AND UNDERSTAND THIS MANUAL PRIOR TO OPERATING OR SERVICING THIS PRODUCT.





We,

**DESIGN CENTER/MANUFACTURER:** SPX Flow Technology Germany GmbH  
Gottlieb-Daimler-Str. 13, D-59439 Holzwickede

**MANUFACTURING FACILITY:** SPX Flow Technology Poland sp. z o.o.  
Rolbieskiego 2, 85-862 Bydgoszcz, Poland

**AUTHORIZED REPRESENTATIVE:** SPX Flow Europe Ltd.  
(for UKCA) Building A, Compass House, Manor Royal  
Crawley, RH10 9PY

declare under our sole responsibility that the

**APV double seal and double seat valves** of the series  
SD4, SDT4, SDU4, SDMS4, SDMSU4, SDTMS4, SWcip4, DSV, DA4, DA4 DPF, D4 SL, DU4  
SL, DT4 SL, DP4 SL, D4, DA3, DA3SLD, DE3, DEU3, DET3, DKR2, DKRT2, DKRH2

**APV butterfly valves** of the series SV1, SVS1F, SV2, SVS2F, SVL, SVSL, SVE, SVSE

**APV ball valves** of the series BLV1

**APV single seat, diaphragm and spring loaded valves** of the series  
S2, SW4, SWhp4, SW4DPF, SWmini4, SWT4, SWS4, MF4, MS4, MSP4, AP/T1, CPV, RG4,  
RG4DPF, RGMS4, RGE4, RGE4DPF, RGEMS4, PR2, PRD2, SI2, UF/R3, UF/R4, VRA/H

and the valve manifolds installed thereof

**meet the requirements of the Machinery Directive 2006/42/EC**  
& EN ISO 12100-2010, DIN EN ISO 14159-2008-07, DIN EN 1672-2-2009-07.

Holzwickede, November 2022



Dr.-Ing. Behdad Ariatabar, Design Center Lead - Valves

**meet the requirements of the Supply of Machinery (Safety) Regulations 2008 No. 1597**  
& BS harmonized standards.

Crawley, November 2022

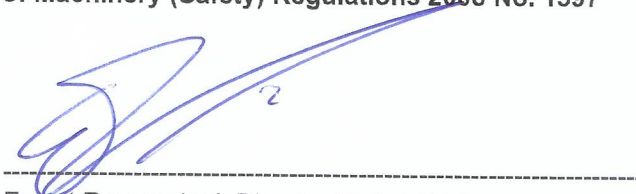

Ewout Roozendaal, Director Global Pricing



<b>Content</b>	<b>Page</b>
<b>1. General Terms</b>	<b>2</b>
<b>2. Safety Instructions</b>	<b>2</b>
<b>3. Intended Use</b>	<b>3</b>
<b>4. Mode of Operation</b>	<b>3</b>
4.1. General terms	
<b>5. Auxiliary Equipment</b>	<b>4 - 5</b>
5.1. Proximity switch holder (PSH)	
5.2. Control unit	
5.3. SWT4 variants	
<b>6. Cleaning</b>	<b>5</b>
<b>7. Installation</b>	<b>6 - 7</b>
7.1. Connections (threaded connections/clamp flange connections)	
7.2. Tank-bottom welding flange	
7.3. Welding instructions	
<b>8. Dimensions / Weights</b>	<b>8</b>
<b>9. Technical Data</b>	<b>9 - 11</b>
9.1. General terms	
9.2. Compressed air quality	
9.3. Product pressures	
9.4. Valve stroke	
9.5. kvs values in m <sup>3</sup> /h	
9.6. Closing times	
<b>10. Maintenance</b>	<b>12</b>
<b>11. Service Instructions</b>	<b>13 - 15</b>
11.1. Dismantling from the line system	
11.2. Disassembly of wear parts (product-wetted parts)	
11.3. Installation of seals and assembly of valve	
11.4. Installation of valve	
<b>12. Service Instructions - Actuator</b>	<b>16</b>
12.1. Maintenance of actuator	
12.2. Installation of seals and assembly of actuator	
12.3. Actuator with valve position feedback	
<b>13. Assembly tool for seat seal</b>	<b>17</b>
<b>14. Trouble Shooting</b>	<b>18</b>
<b>15. Spare Parts Lists</b>	
<b>SWT4 DN 25-100, Inch 1-4</b>	<b>RN 01.054.823</b>
<b>SWT4 DN 125, 150</b>	<b>RN 01.054.823-1</b>
<b>SWT4 DN 125, 150 with manual operation</b>	<b>RN 01.054.823-2</b>
<b>Actuator</b>	<b>RN 01.054.86</b>



## 1. General Terms

This instruction manual should be read carefully by the competent operating and maintenance personnel.

We point out that we will not accept any liability for damage or malfunctions resulting from the non-compliance with this instruction manual.

Descriptions and data given herein are subject to technical changes.

## 2. Safety Instructions



- Danger!**
- The technical safety symbol draws your attention to important directions for operating safety. You will find it wherever the activities described are bearing risks of personal injury.



- The valve must only be assembled, disassembled and reassembled by persons who have been trained in APV valves or by SPX FLOW service team members. If necessary, contact your local SPX FLOW representative.



- **Depressurize** the line and cleaning system before any maintenance work. Drain the lines if possible.
- Observe service instructions to ensure safe maintenance of the valve.



- Separate electric and pneumatic connections.
- **Do not reach into the open valve.**  
Risk of injury by sudden valve operation. In dismantled state there is the risk of bruising at movable parts of the valve.



- **Attention!**  
Valve design NC (normally closed): Before releasing the housing clamp connection, the valve insert must be relieved by controlling the actuator.



- **Attention!**  
Welded actuators are preloaded by spring force.

**Opening of the actuators is strictly forbidden.  
Danger to life!**

Actuators which are no longer used and / or defective must be disposed in professional manner.

Defective actuators must be returned to your local SPX FLOW site for their professional disposal and free of charge for you.

Please address to your local SPX FLOW representative.

## 3. Intended Use

The intended use as field of application of the DELTA SWT4 tank outlet valve is the shut-off between tank and the pipeline sections. Its use is permissible only within the admissible pressure and temperature margins.

Arbitrary constructive changes at the valve will influence safety as well as the intended functionality of the valve and are **not** permissible.

### Authorizations

3-A Sanitary Standards, Inc.

## 4. Mode of Operation

valve illustration  
actuator normally closed : FS (NC)

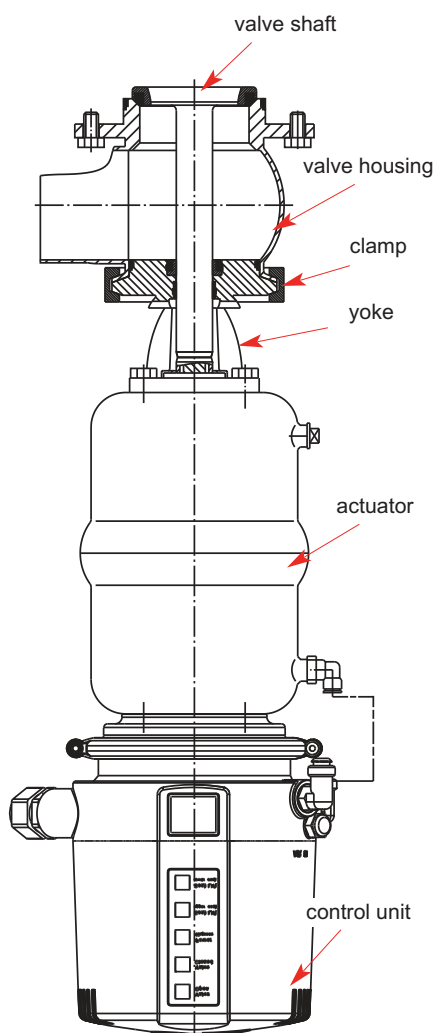

### 4.1. General terms

DELTA SWT4 tank outlet valves have been developed for use in the brewing and beverage industry, in the dairy and food sectors as well as in the chemical and pharmaceutical industries.

The valves are designed for universal applications and stand out for their increased mechanical reliability and absolute ease of handling.

- Operation by pneumatic actuator with air connection, reset by spring force.
- By different assembly of the actuator, the following designs are possible:
  - NC:** actuator normally closed / air-to-raise, spring-to-lower
  - NO:** actuator normally open / air-to-lower, spring-to-raise
- The inner parts of the actuator need not be serviced.
- As standard design for the pneumatic valve control, the valve is equipped with a control unit CU41 being placed on the actuator.
- The luminous diodes in the control unit indicate the position of the valve shaft.



## 5. Auxiliary Equipment

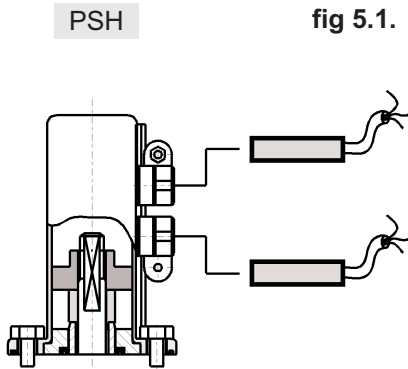

### 5.1 Valve position indication PSH (fig 5.1)

- Alternatively to the control unit, proximity switch holders (PSH) to signal the valve position can be mounted to the actuator. Proximity switches to signal the limit position of the valve disk can be mounted to the proximity switch holder if required.

We recommend to use our APV standard type:

#### Three-wire proximity switch

Operating distance: 5 mm / diameter: 11 mm

Operating voltage: 10 - 30 V DC

pnp positive switching, closing function

Installation „non-flush”

Using a valve position indicator other than APV, we cannot accept any liability for a faultless function.

### 5.2. Control Unit (fig 5.2)

For the start-up as well as assembly and disassembly of the different designs please use the respective manual.

The following different designs are available:

fig 5.2.



<b>CU4 - Direct Connect</b> ref. No.; Ident-No.	CU41 - S Direct Connect 08-45-100/93; H320460
<b>CU4 - AS-interface 62 Slaves</b> ref. No.; Ident-No.	CU41 - S - AS-i extended 08-45-110/93; H320467
<b>CU4 - AS-interface 31 Slaves</b> ref. No.; Ident-No.	CU41 - S - AS-i standard 08-45-250/93; H324673
<b>CU3 - Profibus</b> ref. No.; Ident-No.	CU31 Profibus 08-45-001/93; H315495
<b>CU3 - Device Net</b> ref. No.; Ident-No.	CU31 Device Net 16-31-240/93; H209422

- For the assembly of a control unit on the SWT4 valve an adapter is required.

	adapter
<b>Designation</b> ref. No.; Ident-No.	CU4-S-adapter 08-48-600/93; H320474
<b>Designation</b> ref. No.; Ident-No.	CU3 - adapter SW4 / M4 08-48-480/93; H315806

---

## 5. Auxiliary Equipment

---

fig 5.3.

SWT4- with  
manual operation

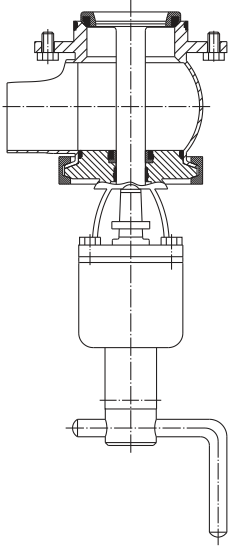

### 5.3. SWT4 variants

- DELTA SWT4 with manual operation (fig 5.3)
- DELTA SWT4 DN 125-150

---

## 6. Cleaning

---

### 6.1. Cleaning Recommendation

Cleaning of the inner valve is effected during the CIP cleaning of the line system.

The valve passages are cleaned during the cleaning of the connected pipelines or by the cleaning liquid of the tank cleaning process.

Depending on the degree and substances of soiling, different cleaning liquids, times and processes must be scheduled for the individual application.

The compatibility of the individually selected cleaning processes and liquids with the respectively used seal materials must be verified.

## 7. Installation

- Installation must be undertaken in such a way that liquids can drain off the valve housing and should preferably be carried out in vertical installing position.



- The valve housing **cannot** be welded direct into the pipeline. At the side ports of the valve housing separate connections (flanges, unions or clamps) must be provided.  
**See fig 7.**

fig 7.

housing  
SWT 41

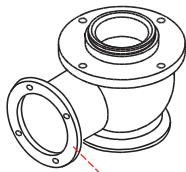

separate connection

housing  
SWT 42

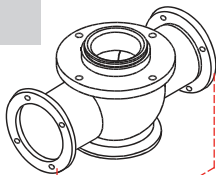

separate connection

e.g. FGN1

### 7.1. Connections:

Besides the housings with weld ends, the following connections are alternatively available:

- male part to DIN 11851
- male part IDF / ISS to ISO 2853
- male part RJT acc. to BS 4825-5
- male part SMS
- male part to DS 722
- flange connection FGN1 DIN
- flange connection FGN1 Inch
- clamp connection to DIN 32676
- clamp connection to ISO 2852

### 7.2. Tank bottom welding flange (fig 7.2.)

**The tank bottom welding flange for the SWT4 valve does not form part of the scope of supply.**

Order reference numbers for the tank bottom welding flange:

DN	Inch	ref.-No.; ID-No.
25	1"	31B 15 - 01 - 291/42; H157266
40	1,5"	31B 15 - 01 - 291/42; H157266
50	2"	31B 15 - 01 - 391/42; H157269
65	2,5"	31B 15 - 01 - 441/42; H157270
80	3"	31B 15 - 01 - 491/42; H157260
100	4"	31B 15 - 01 - 641/42; H157271

tank bottom welding flange

fig 7.2.

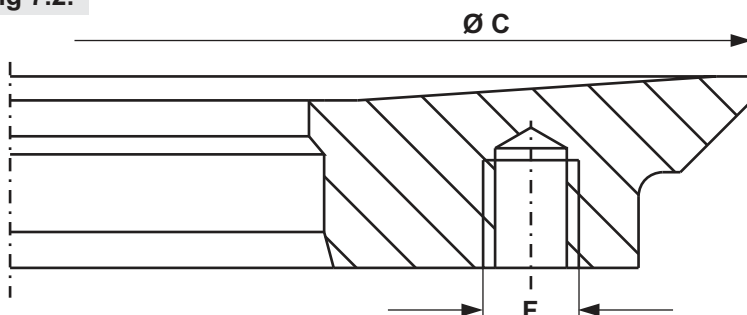

DN	Inch	Ø C	F
25	1"	128	M8
40	1,5"	128	M8
50	2"	148	M8
65	2,5"	168	M8
80	3"	188	M8
100	4"	258	M10

---

## 7. Installation

---

### 7.3 Welding instructions SWT4

- **Tank bottom flange:**  
Dismantle the tank bottom flange from the valve housing.  
See to the positions of the holes (position of valve housing ports) during welding.
- **Valve housing:**  
Before welding of the connections to the valve housing, take the valve insert out of the housing. Remove the housing seal from the tank bottom flange. See to a careful dismantling of the valve insert to avoid damage.
- Welding may only be carried out by certified welders (DIN EN ISO 9606-1). (seam quality DIN EN ISO 5817).
- The welding of the separate connections must be undertaken in such a way that deformation strain cannot be transferred from the outside to the valve body.
- The preparation of the weld seam up to 3 mm thickness must be carried out in butt manner as a square butt joint without air.  
Consider shrinkage!
- TIG orbital welding is best.
- After welding of the valve housings or of the mating flanges and after work at the pipelines, the corresponding parts of the installation or pipelines must be cleaned from welding residues and soiling.  
If these cleaning instructions are not observed, welding residues and dirt particles can settle in the valve and cause damage.
- Any damage resulting from the nonobservance of these welding instructions is not subject to our guarantee.

## 8. Dimensions / Weights

### DELTA SWT4 with control unit CU4

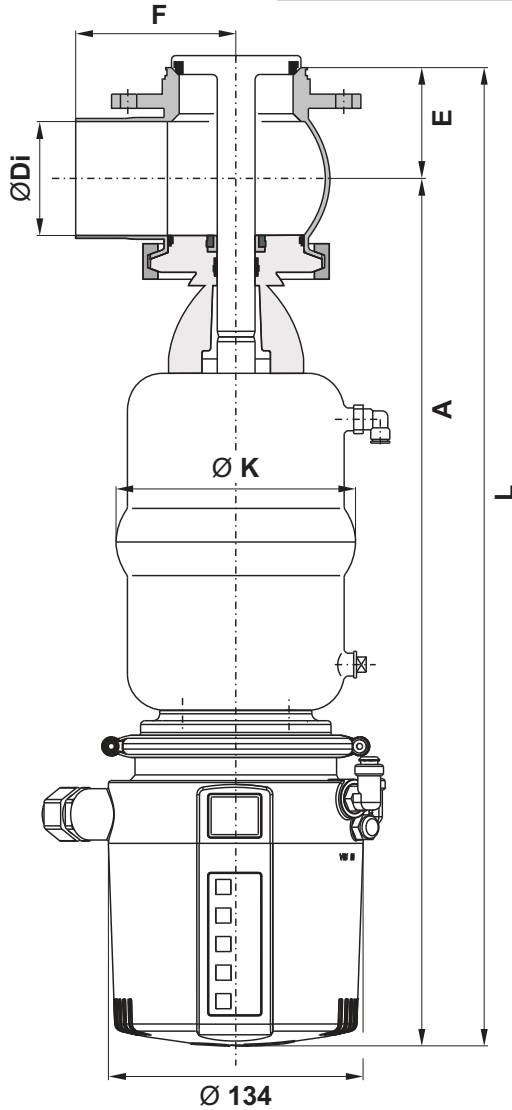

### valve position indication PSH

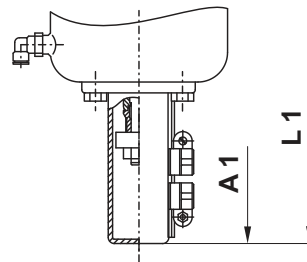

### housing variants

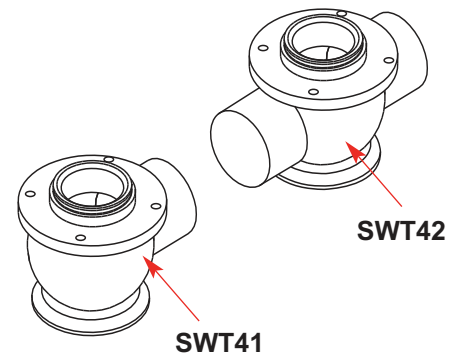

### dimensions in mm

DN	Ø Di	E	F	Ø K	A	L	A1	L1	weight in kg
25	26	41,5	50	86	410	451,5	338	379,5	5
40	38	47,5	67	86	414	461,5	342	389,5	5
50	50	53,5	72	126	451	504,5	379	432,5	7
65	66	61,5	85	126	459	520,5	387	448,5	7
80	81	69,0	98	189	512	581,0	440	509,0	13
100	100	78,7	111	189	522	600,7	450	528,7	15
<b>Inch</b>									
1"	22,6	39,8	50	86	408	447,8	336	375,8	5
1,5"	34,9	45,9	67	86	412	457,9	340	385,9	5
2"	47,6	52,3	72	126	450	502,3	378	430,3	7
2,5"	60,3	58,6	85	126	456	514,6	384	442,6	7
3"	72,9	64,9	98	189	507	571,9	435	499,9	13
4"	97,6	77,3	111	189	520	597,3	448	525,3	15

## 9. Technical Data

### 9.1. General terms

product - wetted parts :	316 L, 1.4404 (DIN EN 10088)
other parts :	1.4301 (DIN EN 10088)
seals: standard design :	EPDM
options:	FPM, VMQ, HNBR
max. product pressure :	10bar
max. operating temperature :	135°C EPDM, HNBR *FPM, *VMQ
short-term load :	140°C EPDM, HNBR *FPM, *VMQ *(no steam)
air connection (for hose) :	6x1mm
max. pneumatic air pressure :	8 bar
min. pneumatic air pressure :	6 bar

### 9.2. Compressed air

quality:	Quality class acc. to DIN ISO 8573-1
- content of solid particles:	quality class 3, max. size of solid particles per m <sup>3</sup> 10000 of 0,5 µm < d < 1,0 µm 500 of 1,0 µm < d < 5,0 µm
- content of water:	quality class 4, max. dew point temperature + 3°C For installations at lower temperatures or at higher altitudes, additional measures must be considered to reduce the pressure dew point accordingly.
- content of oil:	quality class 1, max. 0,01mg/m <sup>3</sup>

The oil applied must be compatible with Polyurethane elastomer materials.

## 9. Technical Data

### 9.3. DELTA SW4 mathematical product pressure in (bar) at 6 bar pneumatic air pressure

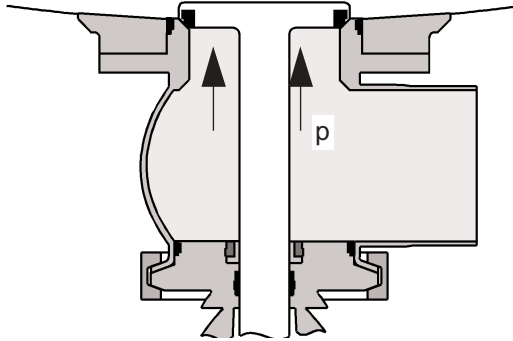

		valve normally closed (NC) without NOT - Element		
		Ø actuator in mm		
DN	Inch	Ø 74 mm	Ø 110 mm	Ø 165 mm
25	1"	<b>21,2 bar</b>	16,0 bar	
40	1,5"	<b>6,0 bar</b>	8,8 bar	
50	2"	3,3 bar	<b>6,0 bar</b>	22,8 bar
	2,5"	2,2 bar	<b>5,0 bar</b>	15,3 bar
65		1,8 bar	<b>4,1 bar</b>	12, bar7
	3"		3,3 bar	<b>10,6 bar</b>
80			2,1 bar	<b>8,4 bar</b>
100	4"			<b>5,5 bar</b>

### 9.4. DELTA SW4 valve stroke

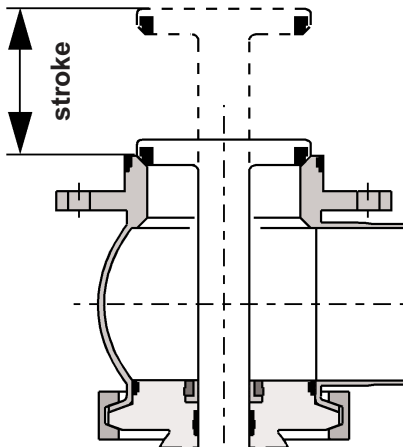

DN	Inch	stroke in mm
25	1"	26
40	1,5"	28
50	2"	28
65	2,5"	28
80	3"	28
100	4"	28

## 9. Technical Data

### 9.5. DELTA SWT4 kvs - values in m<sup>3</sup>/h

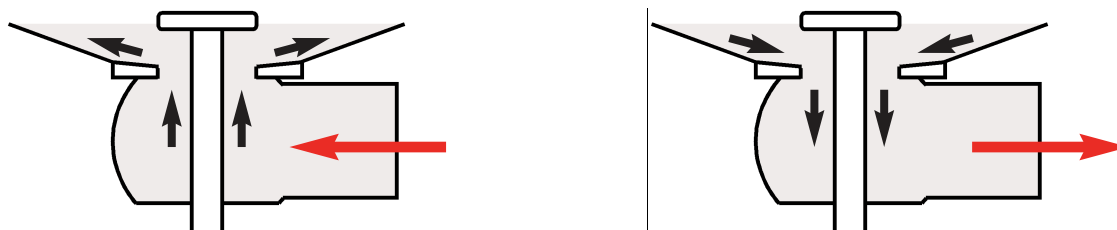

DN	filling	emptying
25	14	13
40	33	31
50	58	51
65	100	89
80	160	137
100	245	212
inch		
1"	10	10
1,5"	30	28
2"	54	49
2,5"	87	76
3"	137	114
4"	225	210

### 9.6. Closing times for tank outlet valve SWT4

The opening and closing times of the valves with control unit can be fixed by adjusting the throttle screw at the solenoid valve.

closing times in sec. pneumatic air pressure 6 bar			
		hose length	
DN	Inch	1 m	10 m
25	1"	1	2
40	1,5"	1	2
50	2"	3	4
65	2,5"	3	4
80	3"	5	6
100	4"	5	6



## 10. Maintenance

- The maintenance intervals are different depending on the application and should be determined by the user carrying out temporary checks.
- The valve must not be cleaned with products containing abrasive or polishing material. Especially the valve shaft must not, under any circumstances, be cleaned with such products. Damage to the valve shaft may cause leakages.



### Required tools:

- 1x wrench SW13
- 1x wrench SW17
- 1x wrench SW19
- 2x wrench SW30
- assembly tool for seat seal (see chapter 13.)
- cleaning rag as well as low-concentrate solution of a suitable cleaning agent.
- Change of seals according to Service Instructions. The customer should keep spare seals on stock. For valve service actions, complete seal kits including seal grease (see spare parts lists) can be supplied.
- Assembly of valve and change of valve design, see Service Instructions.
- Provide all seals with a thin layer of grease before their installation!!!!

### Recommendation:

#### APV assembly grease for EPDM, HNBR, FPM and NBR

(0,75 kg/can - ref.-No. 000 70-01-019/93; H147382)

(60 g/tube - ref.-No. 000 70-01-018/93; H147381)

or

#### APV assembly grease for VMQ

(0,6 kg/can - ref.-No. 000 70-01-017/93; H147380)

(60 g/tube - ref.-No. 000 70-01-016/93; H147379)

- !!! Do **not** use grease containing mineral oil for **EPDM** seals.
- !!! Do **not** use Silicone-based grease for **VMQ** seals.

## 11. Service Instructions

### DELTA SWT4 with control unit CU4

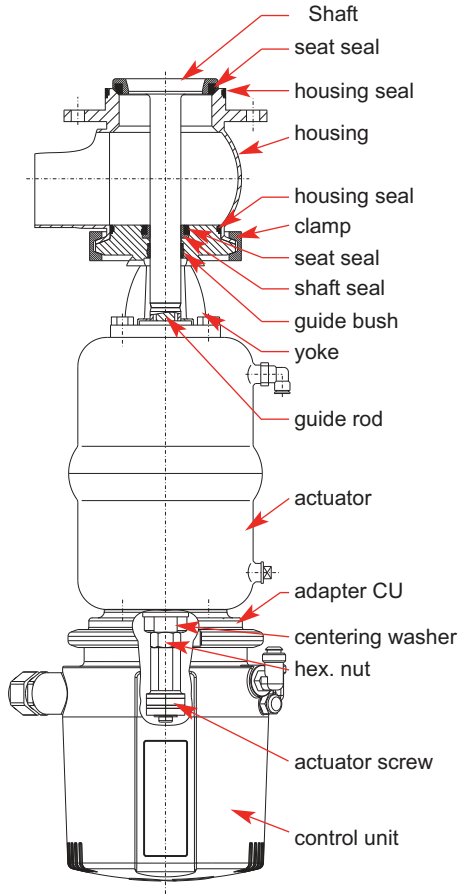

### Design with valve position indicator

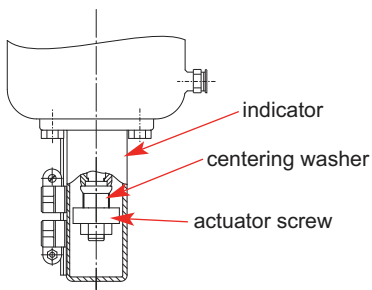

### 11.1. Dismantling from the line system

1. Shut off line pressure and drain off tank.
2. Detach separate connections at the side ports of the valve housing. Remove hex. screws from the tank bottom flange.
3. Pull the complete valve carefully out of the tank bottom flange.

- **Design with control unit:**  
Dismantle the control unit.
- **Design with valve position indicator:**  
Dismantle the proximity switches. Detach the indicator housing (proximity switch holder) from the actuator.

### 11.2. Dismantling of wear parts (product-wetted parts)

1. Valve design NC: Control actuator with air.



**Do not reach for movable valve parts!**  
**Risk of injury by sudden valve actuation.**

- **Design with CU:**  
Undo the actuator screw. Unscrew the hexagon nut while holding up the centering washer. Dismantle the centering washer.
  - **Design with valve position indicator:**  
Undo the actuator screw while holding up the centering washer. Detach centering washer.
2. Shut off compressed air and remove compressed air supply.
  3. Pull valve shaft with guide rod out of the actuator. Remove the seat seal.
  4. Remove the clamp.
  5. Lift actuator with yoke out of the valve housing. Dismantle the housing seal from the valve housing.
  6. Unscrew the yoke from the actuator. Remove housing seal, guide bush, seat seal and shaft seal from the yoke.
  7. Clean the valve housing, yoke, actuator, valve shaft with a low-concentrate solution of a cleaning agent. Never use cleaning agents containing abrasive or polishing material.

## 11. Service Instructions

### 11.3. Installation of seals and assembly of valve

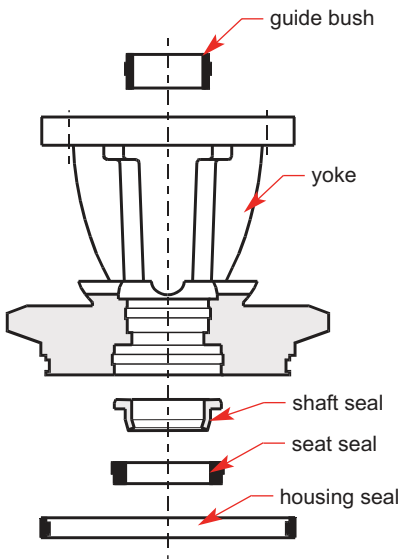

1. Insert the guide bush into the yoke.  
Place the shaft seal and press in the slightly greased seat seal.  
**See to the correct installing direction.**
2. Slightly grease the housing seal and insert it into the groove of the yoke. Install the yoke at the actuator.
3. Put the yoke with actuator in the valve housing and fasten it with the clamp.
4. Insert the seat seal into the shaft. Use the APV assembly tool, see chapter 13, to install the seat seal. Slightly grease the seat seal before its installation.  
If installed manually, vent the seal groove with a thin object between the seal and groove wall.
5. Connect compressed air supply.
6. **Valve design NC: Control actuator with air.**



**Do not touch movable parts!**  
**Risk of injury by sudden valve actuation.**

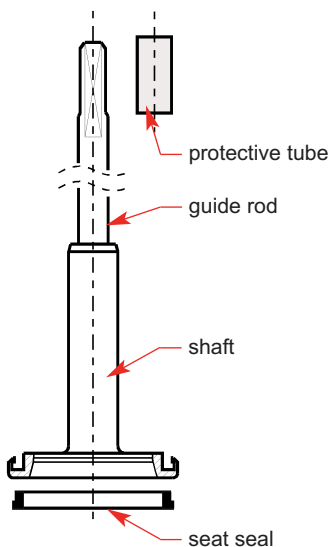

7. Pull the protective pipe via the thread of the guide rod.  
Push the shaft through the housing, yoke and actuator, place the centering washer and fasten it with the hex. nut.  
Hold up the centering washer during this process.  
**Tightening torque: 40 Nm.**
8. **Valve design NC : Shut off compressed air supply.**
9. Slightly grease the housing seal and insert it into the groove of the valve housing.

---

## 11. Service Instructions

---

### 11.4. Installation of valve

1. Install the adapter for the control unit on the actuator.  
Fasten the actuator screw with Loctite on the guide rod.
  - Recommendation: Loctite
  - Type: Loctite 243 semi-solid  
(50ml - ref.-No. 00070-01-111/93; H206336)
2. Place the control unit on the adapter and secure it with the fastening ring.
3. Carefully insert the valve into the tank bottom flange and tighten it with the hex. screws.  
Do not damage the housing seal during this process.
4. Fasten the separate connections at the valve housing.
5. Connect compressed air supply.
6. **Check basic adjustment of the valve position feedback.**
  - The shift points can be adjusted by turning the positioning screw in the control unit.

## 12. Service Instructions - Actuator

### 12.1. Maintenance actuator

1. Remove the air hoses from the actuator.
2. Remove inner hex. screws from the adapter of the control unit.
3. Unscrew the two seal screws with a spanner SW30 while holding up the actuator with a strap wrench.

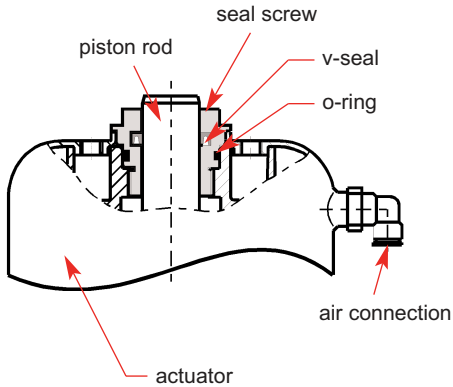

### 12.2. Installation of seals and assembly of actuator

1. Install the greased o-rings and v-seals in the seal screws (fig. 12.2) **See to the correct installing direction of the v-seal.**
2. Slide the seal screws over the piston rod at both sides of the actuator and tighten them.
3. Fasten the adapter for the Control Unit and the yoke on the actuator.

**Attention:** Observe position of adapter.

**Attention:** Consider the required valve design NC or NO during the installation of the adapter and yoke.  
 NC = normally closed / air-to-raise, spring-to-lower  
 NO = normally open / air-to-lower, spring-to-raise

4. Fasten air hoses.

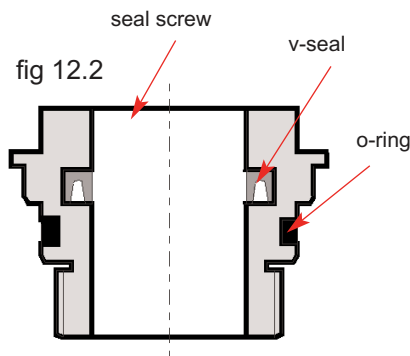

### 12.3. Actuator with valve position indicator (PSH) Assembly of holder

1. Install the actuator screw on the actuator.
2. Equip the housing with the o-ring.
3. Fasten the housing by means of the 4 hex. screws M8 on the actuator.
4. Release the screws at the proximity switch holder and insert the corresponding proximity switches. Then fasten the screws.
5. Place the actuator in one limit position.
6. Place the corresponding proximity switch in the corresponding position. Release the positioning screw and move the holder until the corresponding signal is indicated. Then continue the movement by 2 to 3 mm to secure indication. Fasten the positioning screw.
7. Place the actuator in the other limit position and carry out positioning of the second proximity switch.

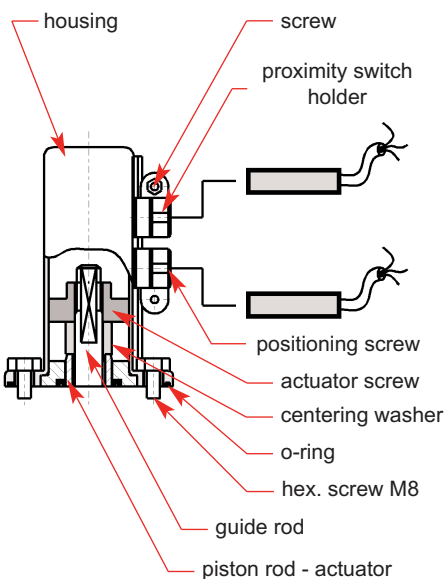

## 13. Assembly Tool for Seat Seal

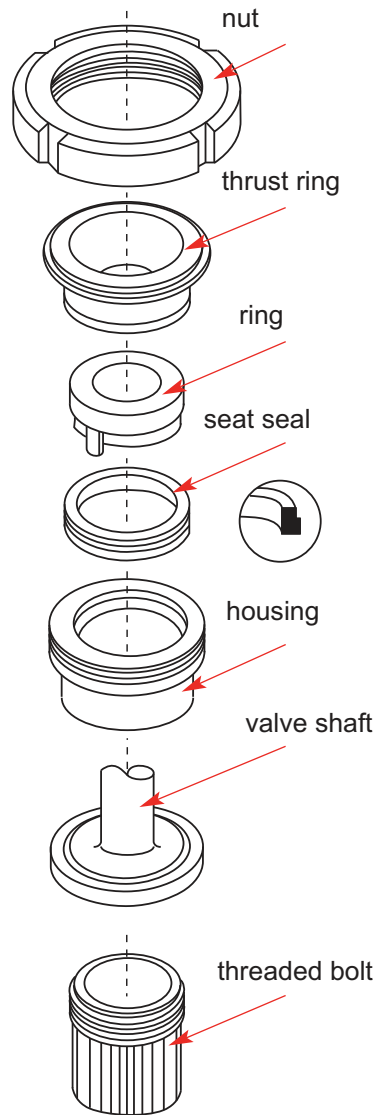

### The assembly tool consists of:

- nut
- thrust ring
- ring with venting nose
- housing
- threaded bolt

### Installation of the seat seal in the valve shaft

1. Insert the valve shaft into the housing in such a way that the seal groove is in the housing.
2. Clamp the shaft into the housing by means of the threaded bolt. Clamp the housing into a vice.
3. Slightly grease the seat seal with APV assembly grease. Then install the seal on the ring with the venting nose until it stops.
4. Introduce the ring with the installed seat seal into the housing and press it down until it stops sensibly.
5. Insert the thrust ring into the housing. Screw on the nut and tighten it with a hook spanner until it stops.
6. Release the nut. Take ring and thrust ring off the housing.
7. Take housing out of the vice, take off the threaded bolt. Detach the valve shaft from the housing.

### Check the even fit of the seat seal.

### Assembly tool for seat seal

To simplify the installation of the seat seal, the following assembly tools are available:

assembly tool SW4		
DN	Inch	reference No.:
25	1"	51-13-110/17; H179465
40	1,5"	51-13-111/17; H179466
50	2"	51-13-112/17; H179467
	2,5"	51-13-120/17; H179468
65		51-13-113/17; H179469
	3"	51-13-121/17; H179470
80		51-13-114/17; H179471
100	4"	51-13-115/17; H179472

## 14. Trouble Shooting

Failure	Remedy
<b><i>Valve closed, pressure in tank</i></b>	
Leakage between tank bottom flange and valve housing flange	<b>Replace housing seal.</b>
<b><i>Valve closed, pressure in housing</i></b>	
Leakage in clamp area and valve housing.	<b>Replace housing seal. Check line pressure: permissible line pressure, see table page 10</b>
Leakage at the upper valve shaft in valve yoke area.	<b>Replace shaft seal, seat seal and guide bushes.</b>
<b><i>Actuator</i></b>	
Air escapes from actuator rod.	<b>Replace o-ring at the upper side of actuator.</b>
Air escapes from actuator rod. Actuator does not work. (air escapes permanently from vent plug)	<b>Replace the complete actuator.</b>
<b><i>Valve position indication</i></b>	
No feedback.	<b>Carry out fine adjustment.</b>

## 15. Spare Parts Lists

The reference numbers of the spare parts for the different valve designs and sizes are included in the attached spare parts drawings with corresponding lists.

Please indicate the following data to place an order for spare parts:

- number of required parts
- reference number
- designation.

subject to change





Weitergabe sowie Vervielfältigung dieser Unterlage, Verwertung und Mitteilung ihres Inhalts nicht gestattet, soweit nicht schriftlich zugestanden. Verstöß verpflichtet zum Schadensersatz und kann strafrechtliche Folgen haben (Paragraph 18 UWG, Paragraph 106 UrhG). Eigentum und alle Rechte, auch für Patenterteilung und Gebrauchsmustereintragung, vorbehalten. SPX Flow Technology Rosista GmbH.

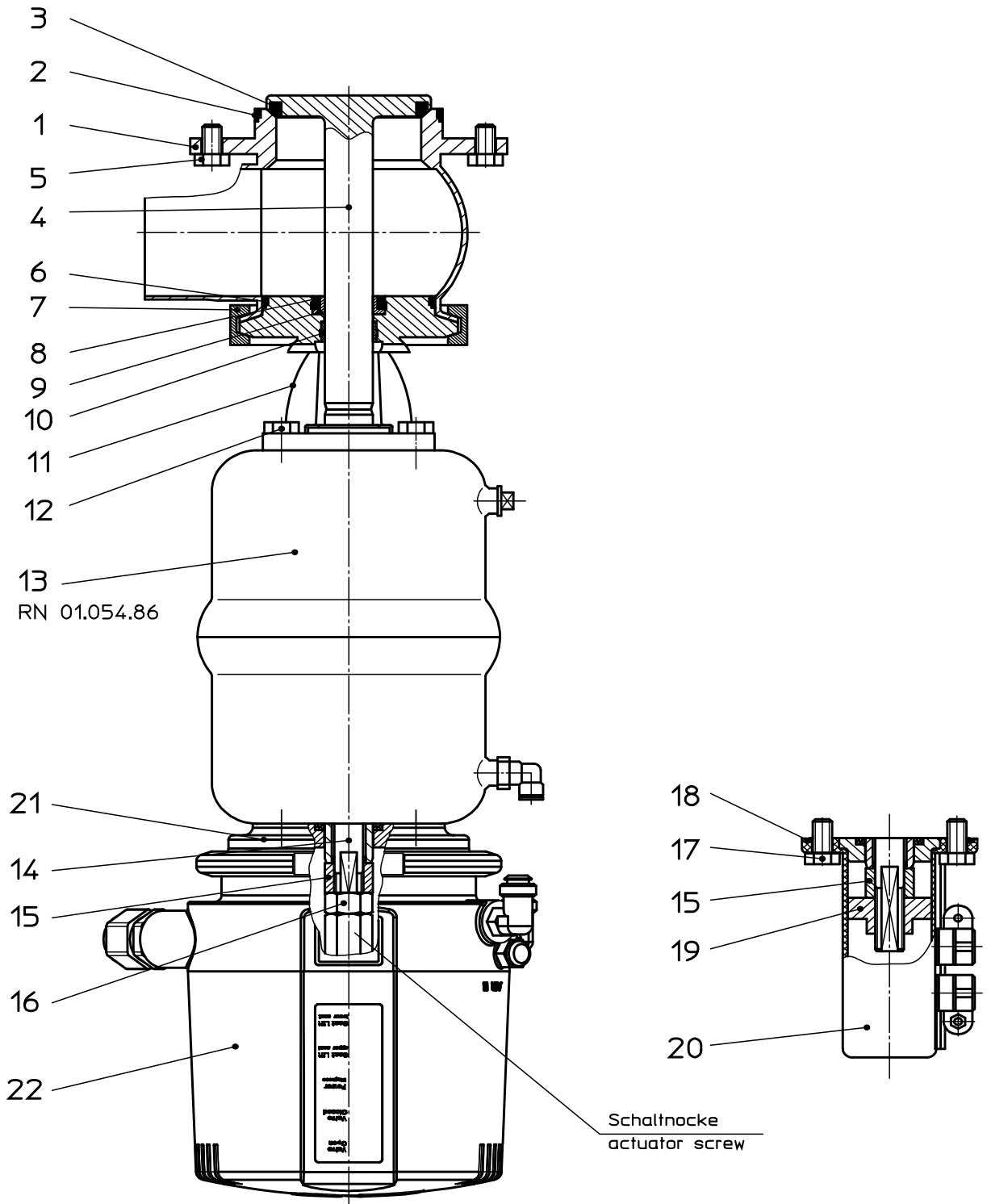

Datum:	07.03.14	23.03.16							
Name:	Trytko	Trytko							
Geprüft:									

Ersatzteilliste: spare parts list

**Ventil SWT41, SWT42 -FS-CU und VSM**  
**Single seat tank outlet valve SWT41, SWT42 -FS-CU and PSH**  
**DN25-100 ; 1-4 zoll / inch**

**APV**

SPX Flow Technology Rosista GmbH  
D-59425 Unna Germany

Blatt 1 von 7

**RN 01.054.823**

Weitergabe sowie Vervielfältigung dieser Unterlage, Verwertung und Mitteilung ihres Inhalts nicht gestattet, soweit nicht schriftlich zugestanden. Verstoß verpflichtet zum Schadensersatz und kann strafrechtliche Folgen haben (Paragraf 18 UWG, Paragraf 106 UrhG). Eigentum und alle Rechte, auch für Patenterteilung und Gebrauchsmustererteilung, vorbehalten. SPX Flow Technology Rosista GmbH.

Ersatzteilliste: spare parts list

**Ventil SWT41, SWT42 -FS-CU und VSM**  
**Single seat tank outlet valve SWT41, SWT42 -FS-CU and PSH**  
**DN25-100 ; 1-4 Zoll / inch**

pos. item	Menge quantity	Beschreibung description	Material	DN25	1"	DN40	1,5"	DN50	2"	Datum: 07.03.14 23.03.16		Blatt 2 von 7	
										WS-Nr. ref.-no.	WS-Nr. ref.-no.	WS-Nr. ref.-no.	WS-Nr. ref.-no.
1	1	Gehäuse Housing SWT41 1S	1.4404	15-71-280/47 H171361	15-71-305/47 H171367	15-71-380/47 H171362	15-71-405/47 H171368	15-71-430/47 H171363	15-71-455/47 H171369				
	1	Gehäuse Housing SWT42 12S	1.4404	15-72-280/47 H172915	15-72-305/47 H172916	15-72-380/47 H172917	15-72-405/47 H172922	15-72-430/47 H172918	15-72-455/47 H172923				
2	1	Gehäusedichtung Housing seal	EPDM FDA-konform		58-33-292/93 H77439				58-33-392/93 H77464				
	1	Gehäusedichtung Housing seal	HNBR FDA-konform		58-33-292/33 H170017				58-33-392/33 H170018				
3	1	Gehäusedichtung Housing seal	FPM FDA-konform		58-33-292/73 H77438				58-33-392/73 H77463				
	1	Tellerdichtung Seat seal	EPDM FDA-konform	58-33-293/93 H77442		58-33-393/93 H77467			58-33-443/93 H77491				
4	1	Tellerdichtung Seat seal	HNBR FDA-konform	58-33-293/33 H170176		58-33-393/33 H166676			58-33-443/33 H166085				
	1	Tellerdichtung Seat seal	FPM FDA-konform	58-33-293/73 H77441		58-33-393/73 H77466			58-33-443/73 H77490				
5	1	Tellerdichtung Seat seal	VMQ FDA-konform	58-33-293/13 H77440		58-33-393/13 H77465			58-33-443/13 H77489				
	1	Schaft Valve shaft	1.4404	15-25-280/42 H171131	15-25-305/42 H171132	15-25-380/42 H171118	15-25-405/42 H171125	15-25-430/42 H171121	15-25-455/42 H171126				
6	4	Skt. Schraube Hex. Screw	1.4301							65-01-079/15 M8x14 H78768			
7	1	Gehäusedichtung Housing seal	EPDM FDA-konform	58-33-267/93 H136432		58-33-292/93 H77439			58-33-124/93 H170665				
	1	Gehäusedichtung Housing seal	HNBR FDA-konform	58-33-267/33 H172124		58-33-292/33 H170017			58-33-124/33 H170654				
8	1	Gehäusedichtung Housing seal	FPM FDA-konform	58-33-267/73		58-33-292/73			58-33-124/73				
	1	Gelenkklemme Clamp	1.4301	42-40-287/12 H126263		42-40-387/12 H126264			42-40-437/12 H126265				
8	1	Tellerdichtung Seat seal	EPDM FDA-konform			58-33-293/93 H77442							



SPX Flow Technology Rosista GmbH  
D-59425 Umma Germany

Ersatzteilliste : spare parts list

**Ventil SWT41, SWT42 -FS-CU und VSM  
Single seat tank outlet valve SWT41, SWT42 -FS-CU and PSH  
DN25-100 ; 1-4 Zoll / inch**

pos. item	Menge quantity	Beschreibung description	Material	DN25	1"	1,5"	DN50	2"	Datum:		APV	
									WS-Nr. ref.-no.	WS-Nr. ref.-no.	Trytko	Trytko
1	1	Tellerdichtung Seat seal	HNBR FDA-konform									
8	1	Tellerdichtung Seat seal	FPM FDA-konform									
	1	Tellerdichtung Seat seal	VMQ FDA-konform									
9	1	Schaftdichtung Shaft seal	Turcon MF6									
10	1	Führungsbuchse Bushing	PTFE + 25% Kohle									
11	1	Laterne Yoke	1.4404	15-40-960/47 H171382					15-40-961/47 H171383			15-40-962/47 H171384
12	4	Skt. Schraube Hex. Screw	1.4301						65-01-081/15 M8x16 H78772			
13	1	Steuerkopf Actuator	1.4301						15-32-050/17 H171378			15-32-051/17 H171379
14	1	Zugstange Guide rod	1.4305						15-23-850/12 H171061			15-23-851/12 H171062
15	1	Zentrierscheibe Centering nut	1.4301						15-28-940/12 H170196			
16	1	Skt. Mutter Hex. Nut	1.4301						65-50-101/15 H79298			
17	4	Skt. Schraube Hex. Screw	1.4301						65-01-081/15 M8x16 H78772			
18	1	O-Ring O-ring	NBR						58-06-297/83 H173930			
19	1	Schaltnocke Operating cam	1.4523						08-52-290/97 H173086			08-52-291/97 H173087
20	1	VSM Gehäuse-SW4 Proximity switch holder housing SW4	VESTAMID						15-33-932/93 H173931			
21	1	CU4-S-Adapter CU4-S-adapter	PA6.6 GF30 schwarz						08-48-600/93 H320474			



Ersatzteilliste: spare parts list

**Ventil SWT41, SWT42 -FS-CU und VSM**  
**Single seat tank outlet valve SWT41, SWT42 -FS-CU and PSH**  
**DN25-100 ; 1-4 Zoll / inch**

Datum:	07.03.14	23.03.16
Name:	Trytko	Trytko
Geprüft:		
Datum:		
Name:		
Geprüft:		

										 SPX Flow Technology Rosista GmbH D-59425 Umma Germany	
										Blatt 5 von 7	
										<b>RN01.054.823</b>	

pos. item	Menge quantity	Beschreibung description	Material	DN65	2.5"	3"	DN80	DN100	4"
				WS-Nr. ref.-no.	WS-Nr. ref.-no.	WS-Nr. ref.-no.	WS-Nr. ref.-no.	WS-Nr. ref.-no.	
1	1	Gehäuse Housing	1.4404	15-71-480/47 H171364	15-71-505/47 H171370	15-71-555/47 H171371	15-71-530/47 H171365	15-71-630/47 H171366	15-71-655/47 H171372
	1	Gehäuse Housing	1.4404	15-72-480/47 H172919	15-72-505/47 H172924	15-72-555/47 H172925	15-72-530/47 H172920	15-72-630/47 H172924	15-72-655/47 H172926
2	1	Gehäusedichtung Housing seal	EPDM FDA-konform	58-33-442/93 H77488	58-33-125/93 H170667	58-33-126/93 H170669	58-33-492/93 H77512	58-33-127/93 H170671	
	1	Gehäusedichtung Housing seal	HNBR FDA-konform	58-33-442/33 H168714	58-33-125/33 H170655	58-33-126/33 H170656	58-33-492/33 H168759	58-33-127/33 H170657	
3	1	Gehäusedichtung Housing seal	FPM FDA-konform	58-33-442/73 H77487	58-33-125/73 H170668	58-33-126/73 H170670	58-33-492/73 H77511	58-33-127/73 H170672	
	1	Tellerdichtung Seat seal	EPDM FDA-konform	58-33-493/93 H77515	58-33-109/93 H170662	58-33-568/93 H77561	58-33-543/93 H77546	58-33-643/93 H77586	
4	1	Tellerdichtung Seat seal	HNBR FDA-konform	58-33-493/33 H166678	58-33-109/33 H170658	58-33-568/33 H166679	58-33-543/33 H166681	58-33-643/33 H166682	
	1	Tellerdichtung Seat seal	FPM FDA-konform	58-33-493/73 H77514	58-33-109/73 H170663	58-33-568/73 H77560	58-33-543/73 H77545	58-33-643/73 H77785	
5	1	Tellerdichtung Seat seal	VMQ FDA-konform	58-33-493/13 H77513	58-33-109/13 H170664	58-33-568/13 H77559	58-33-543/13 H77544	58-33-643/13 H77584	
	1	Schaft Valve shaft	1.4404	15-25-480/42 H171122	15-25-505/42 H171127	15-25-555/42 H171129	15-25-530/42 H171123	15-25-630/42 H171124	15-25-655/42 H171130
5	4	Skt. Schraube Hex. Screw	1.4301	65-01-079/15 M8x14 H78768					65-01-129/15 M10x14 H78805
6	1	Gehäusedichtung Housing seal	EPDM FDA-konform	58-33-442/93 H77488		58-33-492/93 H77512		58-33-642/93 H77583	
	1	Gehäusedichtung Housing seal	HNBR FDA-konform	58-33-442/33 H168714		58-33-492/33 H168759		58-33-642/33/ H170074	
7	1	Gehäusedichtung Housing seal	FPM FDA-konform	58-33-442/73 H77487		58-33-492/73 H77511		58-33-642/73 H77582	
	1	Gelenkklemme Clamp	1.4301	42-40-487/12 H126266		42-40-537/12 H126267		42-40-637/12 H126268	
8	1	Tellerdichtung Seat seal	EPDM FDA-konform			58-33-293/93 H77442			

Weitergabe sowie Vervielfältigung dieser Unterlage, Verwertung und Mitteilung ihres Inhalts nicht gestattet, soweit nicht schriftlich zugestanden. Verstöß verpflichtet zum Schadensersatz und kann strafrechtliche Folgen haben (Paragraf 18 UWG, Paragraf 106 UrhG). Eigentum und alle Rechte, auch für Patenterteilung und Gebrauchsmustereintragung, vorbehalten. SPX Flow Technology Rosista GmbH.

Ersatzteilliste : spare parts list

**Ventil SWT41, SWT42 -FS-CU und VSM**  
**Single seat tank outlet valve SWT41, SWT42 -FS-CU and PSH**  
**DN25-100 ; 1-4 Zoll / inch**

pos. item	Menge quantity	Beschreibung description	Material	DN65	2,5"	3"	DN80	DN100	4"	Datum: 07.03.14 23.03.16		
										WS-Nr. ref.-no.	WS-Nr. ref.-no.	WS-Nr. ref.-no.
	1	Tellerdichtung Seat seal	HNBR FDA-konform							Blatt 6 von 7		
8	1	Tellerdichtung Seat seal	FPM FDA-konform							RN01.054.823		
	1	Tellerdichtung Seat seal	VMQ FDA-konform									
9	1	Schaftdichtung Shaft seal	Turcon MF6									
10	1	Führungsbuchse Bushing	PTFE + 25% Kohle									
11	1	Laterne Yoke	1.4404	15-40-963/47 H171385	15-40-964/47 H171388	15-40-965/47 H171389	15-40-966/47 H171386			15-40-967/47 H171387		
12	4	Skt. Schraube Hex. Screw	1.4301	65-01-081/15 M8x16 H78772						65-01-083/15 M8x20 H78776		
13	1	Steuerkopf Actuator	1.4301	15-32-051/17 H171379						15-32-052/17 H171380		
14	1	Zugstange Guide rod	1.4305	15-23-851/12 H171062						15-23-852/12 H171063		
15	1	Zentrierscheibe Centering nut	1.4301							15-28-940/12 H170196		
16	1	Skt. Mutter Hex. Nut	1.4301							65-50-101/15 H79298		
17	4	Skt. Schraube Hex. Screw	1.4301							65-01-081/15 M8x16 H78772		
18	1	O-Ring O-ring	NBR							58-06-297/83 H173930		
19	1	Schaltnocke Operating cam	1.4523							08-52-291/97 H173087		
20	1	VSM Gehäuse-SW4 Proximity switch holder housing SW4	VESTAMID							15-33-932/93 H173931		
21	1	CU4-S-Adapter CU4-S-adapter	PA6.6 GF30 schwarz							08-48-600/93 H320474		









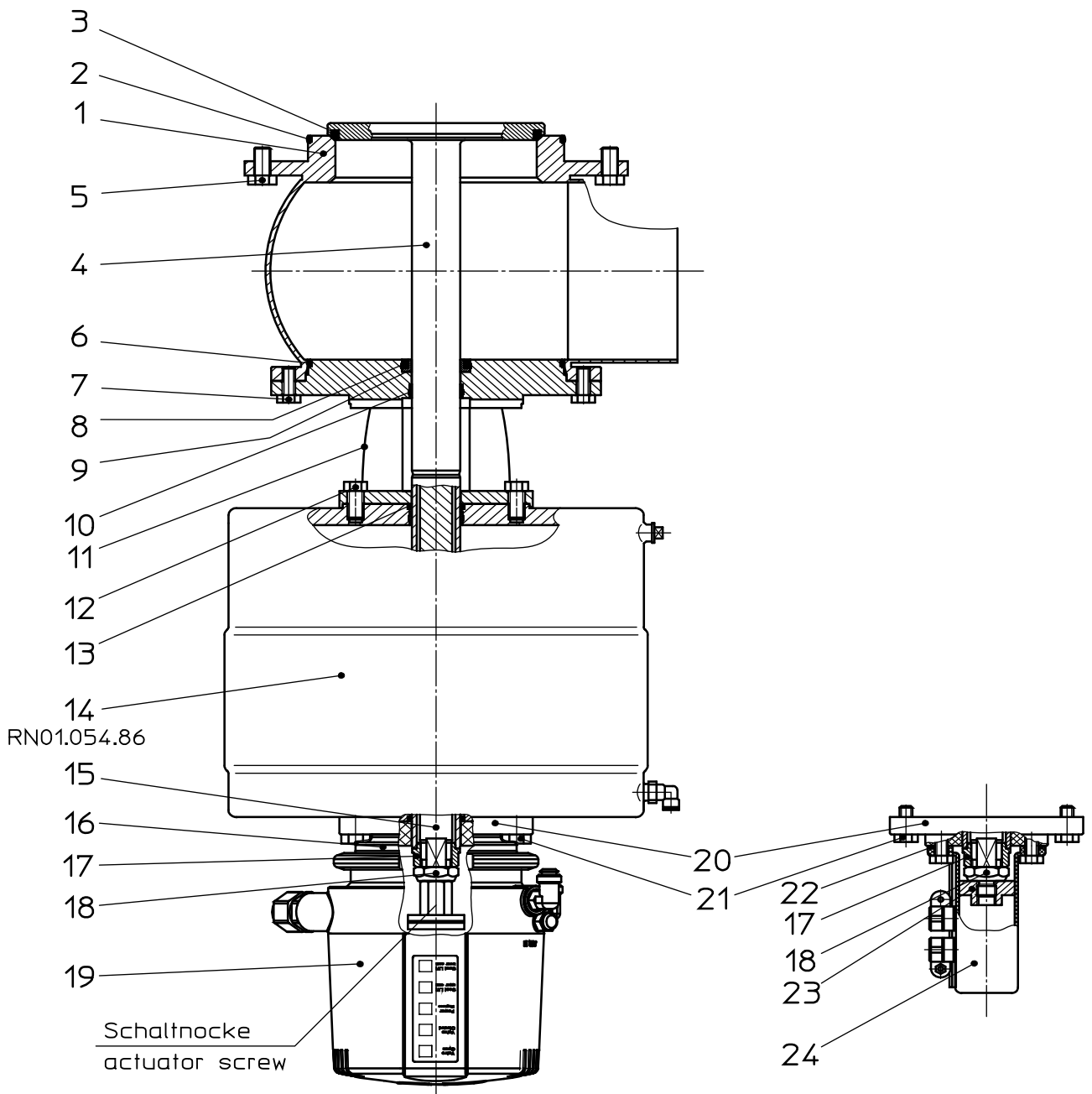

Weitergabe sowie Vervielfältigung dieser Unterlage, Verwertung und Mitteilung ihres Inhalts nicht gestattet, soweit nicht schriftlich zugestanden. Verstöße verpflichten zum Schadensersatz und kann strafrechtliche Folgen haben (Paragraph 18 UWG, Paragraph 106 UrhG). Eigentum und alle Rechte, auch für Patenterteilung und Gebrauchsmustereintragung, vorbehalten. SPX Flow Technology Rosista GmbH.



Datum:	07.03.14									
Name:	Trytko									
Geprüft:										

Ersatzteilliste: spare parts list

**Ventil SWT41, SWT42 -FS-CU und VSM**  
**Single seat tank outlet valve SWT41, SWT42 -FS-CU and PSH**  
**DN125, 150**

  
 SPX Flow Technology Rosista GmbH  
 D-59425 Unna Germany  
 Blatt 1 von 4  
**RN 01.054.823-1**

Weitergabe sowie Vervielfältigung dieser Unterlage, Verwertung und Mitteilung ihres Inhalts nicht gestattet, soweit nicht schriftlich zugestanden. Verstößt verpflichtet zum Schadensersatz und kann strafrechtliche Folgen haben (Paragraf 18 UWG, Paragraf 106 UrhG). Eigentum und alle Rechte, auch für Patenterteilung und Gebrauchsmustereintragung, vorbehalten. SPX Flow Technology Rosista GmbH.

Ersatzteilliste: spare parts list

**Ventil SWT41, SWT42 -FS-CU und VSM**  
**Single seat tank outlet valve SWT41, SWT42 -FS-CU and PSH**  
**DN125, 150**

pos. item	Menge quantity	Beschreibung description	Material	DN125		5"		6"		Date: Datum:	Name: Name:	Checked: Geprüft:
				WS-Nr. ref.-no.	WS-Nr. ref.-no.	WS-Nr. ref.-no.	WS-Nr. ref.-no.	WS-Nr. ref.-no.	WS-Nr. ref.-no.			
1	1	Gehäuse Housing	1.4404	15-71-680/47 H203635	15-71-730/47 H203633	15-71-730/47 H203633				07.03.14	Trytko	
	1	Gehäuse Housing	1.4404	15-72-680/47 H203636	15-712-730/47 H203634	15-712-730/47 H203634						
2	1	Gehäusedichtung Housing seal	EPDM FDA-konform	58-33-692/93 H77608	58-33-742/93 H77625	58-33-742/93 H77625						
	1	Gehäusedichtung Housing seal	HNBR FDA-konform	58-33-692/33 H172125	58-33-742/33 H172126	58-33-742/33 H172126						
3	1	Gehäusedichtung Housing seal	FPM FDA-konform	58-33-692/73 H77607	58-33-742/73 H77624	58-33-742/73 H77624						
	1	Tellerdichtung Seat seal	EPDM FDA-konform	58-33-693/93 H77611	58-33-743/93 H77628	58-33-743/93 H77628						
4	1	Tellerdichtung Seat seal	HNBR FDA-konform	58-33-693/33 H170178	58-33-743/33 H170177	58-33-743/33 H170177						
	1	Tellerdichtung Seat seal	FPM FDA-konform	58-33-693/73 H77610	58-33-743/73 H77627	58-33-743/73 H77627						
5	1	Tellerdichtung Seat seal	VMQ FDA-konform	58-33-693/13 H77609	58-33-743/13 H77626	58-33-743/13 H77626						
	1	Schaft Valve shaft	1.4404	15-25-680/42 H203899	15-25-732/42 H203900	15-25-732/42 H203900						
6	4	Skt. Schraube Hex. Screw	1.4301	65-01-132/15 M10x20 H78809	65-01-132/15 M10x20 H78809	65-01-132/15 M10x20 H78809						
	1	Gehäusedichtung Housing seal	EPDM FDA-konform	58-33-692/93 H77608	58-33-742/93 H77625	58-33-742/93 H77625						
7	1	Gehäusedichtung Housing seal	HNBR FDA-konform	58-33-692/33 H172125	58-33-742/33 H172126	58-33-742/33 H172126						
	1	Gehäusedichtung Housing seal	FPM FDA-konform	58-33-692/73 H77607	58-33-742/73 H77624	58-33-742/73 H77624						
8	8	Skt. Schraube Hex. Screw	1.4301	65-01-132/15 M10x20 H78809	65-01-132/15 M10x20 H78809	65-01-132/15 M10x20 H78809						
	1	Tellerdichtung Seat seal	EPDM FDA-konform	58-33-393/93 H77467	58-33-393/93 H77467	58-33-393/93 H77467						

**APV**  
 SPX Flow Technology Rosista GmbH  
 D-59425 Uнна Germany

Blatt 2 von 4  
**RN01.054.823-1**





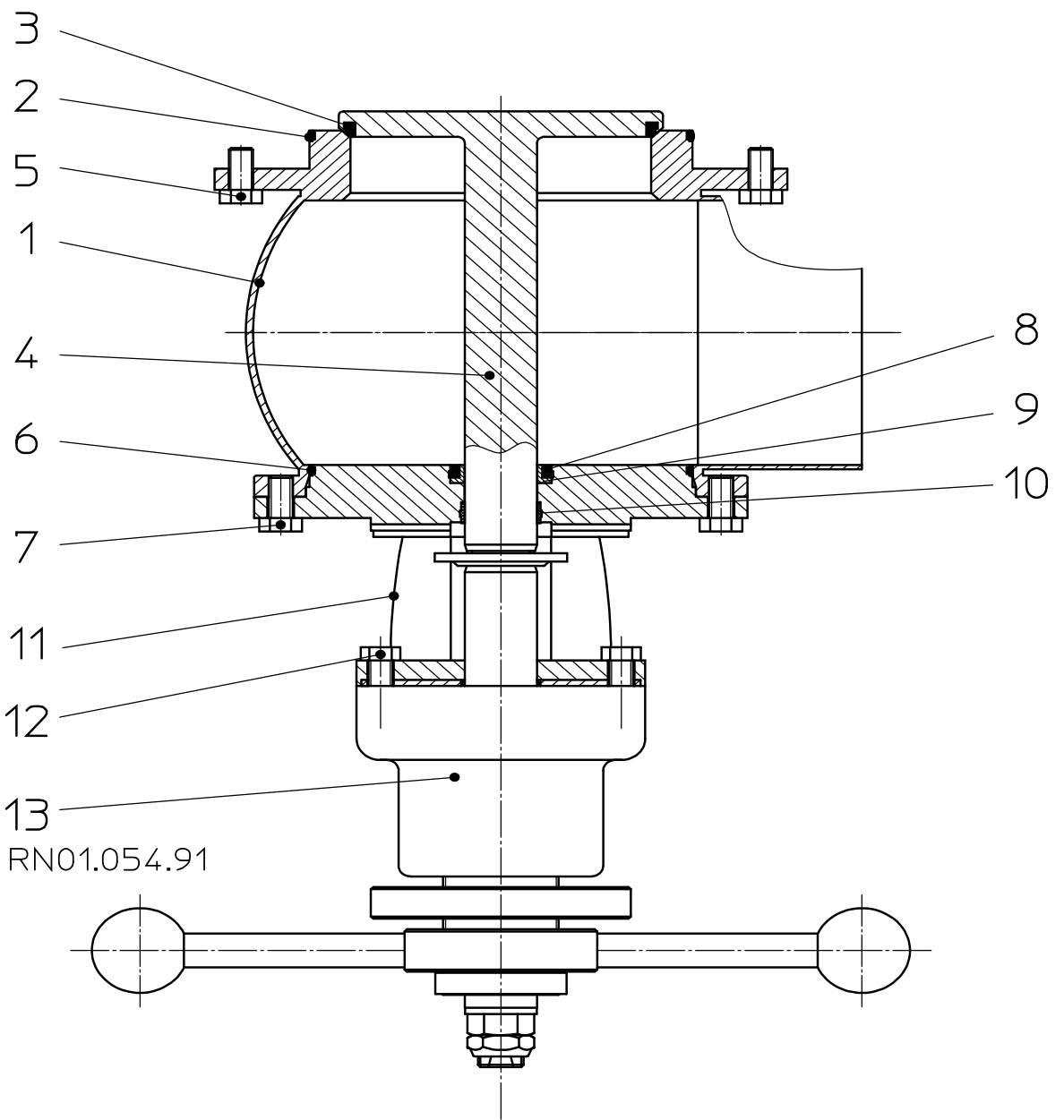

RN01.054.91

Weitergabe sowie Vervielfältigung dieser Unterlage, Verwertung und Mitteilung ihres Inhalts nicht gestattet, soweit nicht schriftlich zugestanden. Verstöß verpflichtet zum Schadensersatz und kann strafrechtliche Folgen haben (Paragraph 18 UWG, Paragraph 106 UrhG). Eigentum und alle Rechte, auch für Patenterteilung und Gebrauchsmustereintragung, vorbehalten. SPX Flow Technology Rosista GmbH.

Datum:	11.02.15										
Name:	Trytko										
Geprüft:											

Ersatzteilliste: spare parts list

**Ventil SWT41, SWT42 mit Handbetätigung**  
**Single seat tank outlet valve SWT41, SWT42 with handle**  
**DN125, 150 ; 6 Zoll / inch**



SPX Flow Technology Rosista GmbH  
D-59425 Unna Germany

Blatt 1 von 3

**RN 01.054.823-2**









Ersatzteilliste: spare parts list

**Steuerkopf SW4  
Actuator SW4**

Datum:	11/08	12/09	27.01.15
Name:	Peters	Peters	Trytko
Geprüft:			
Datum:			
Name:			
Geprüft:			

**APV**  
SPX Flow Technology Rosista GmbH  
D-59425 Umma Germany

Blatt 1 von 1

**RN 01.054.86**

pos. item	Menge quantity	Beschreibung description	Ø 74		Ø 110		Ø 165		
			WS-Nr. ref.-no.	WS-Nr. ref.-no.	WS-Nr. ref.-no.	WS-Nr. ref.-no.			
1	1	Steuerkopf kpl. Feder/Luft - matt glänzend Actuator cpl. Spring/air satin finish	15-32-050/17 H171378	15-32-051/17 H171379	15-32-052/17 H171380				
	1	Steuerkopf kpl. Feder/Luft - 3A-blank Actuator cpl. Spring/air 3A bright	3A0 15-32-059/13 H208693	3A0 15-32-060/13 H173538	3A0 15-32-061/13 H173524				
	1	Steuerkopf kpl. Luft/Luft - matt glänzend Actuator cpl. air/air satin finish	15-32-085/17 H209592	15-32-086/17 H209203	15-32-087/17 H208733				
	1	Steuerkopf kpl. Luft/Luft - 3A-blank Actuator cpl. air/air 3A bright	3A0 15-32-057/13 H208690	3A0 15-32-065/13 H208772	3A0 15-32-066/13 H208773				
2	2	Schraube Dichtung Seal screw	15-28-840/93 H170200						
3	2	V-Dichtung V-seal	58-32-010/83 H171060						
4	2	O-Ring O-ring	58-06-124/83 H171059						

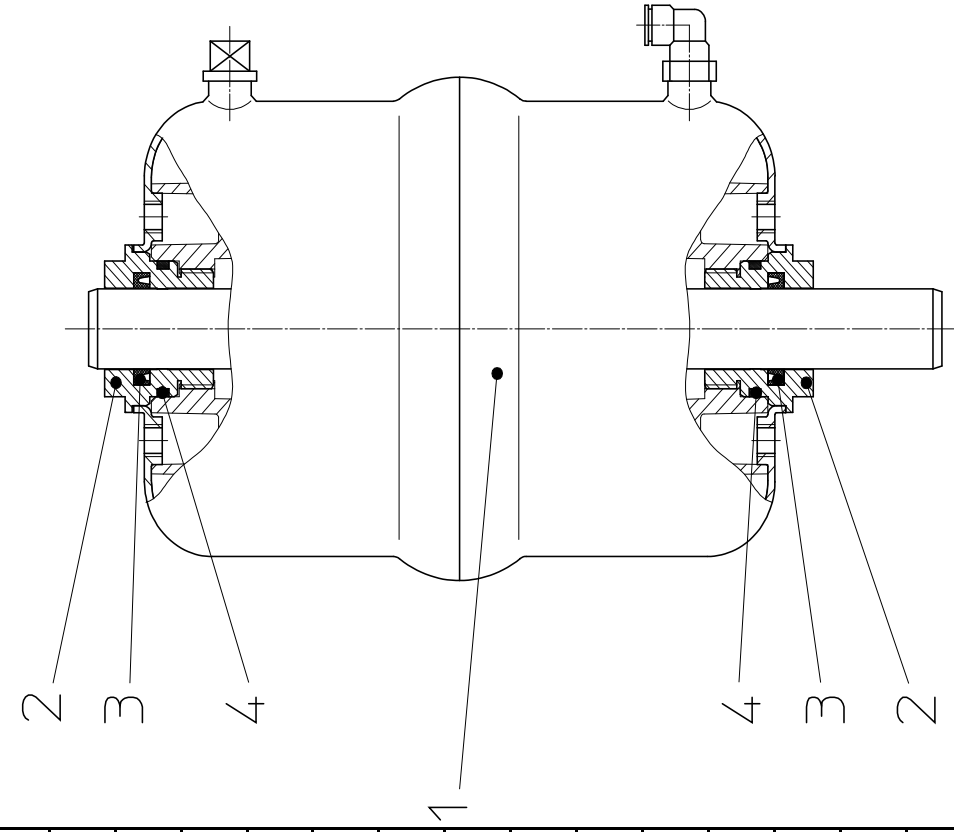

# APV DELTA SWT4

TANK OUTLET VALVE

# SPXFLOW

## SPX FLOW

### Design Center

Gottlieb-Daimler-Straße 13  
D-59439 Holzwickede, Germany  
P: (+49) (0) 2301-9186-0  
F: (+49) (0) 2301-9186-300

## SPX FLOW

### Production

Stefana Rolbieskiego 2  
PL- Bydgoszcz 85-862, Poland  
P: (+48) 52 566 76 00  
F: (+48) 52 525 99 09

SPX FLOW reserves the right to incorporate the latest design and material changes without notice or obligation.

Design features, materials of construction and dimensional data, as described in this manual, are provided for your information only and should not be relied upon unless confirmed in writing. Please contact your local sales representative for product availability in your region. For more information visit [www.spxflow.com](http://www.spxflow.com).

ISSUED 01/2017 - Translation of Original Manual

COPYRIGHT ©2017 SPX FLOW, Inc.